

Stainless Steel- Mini indexing plungers with and without rest position

SPECIFICATION

Types

- Type **B**: without rest position, with plastic knob
- Type **BN**: without rest position, with Stainless Steel knob
- Type **C**: with rest position, with plastic knob
- Type **CN**: with rest position, with Stainless Steel knob

Guide

Stainless Steel AISI 304

Pin

Stainless Steel AISI 303

Spring

Stainless Steel AISI 301

Version with Plastic knob

Knob type B and C

- Plastic (Polyamide PA)
- black, matt
- not removable

Version with Stainless Steel knob

Knob type BN and CN

- AISI CF-8
- matt, blasted
- not removable



INFORMATION

Stainless Steel-Mini indexing plungers GN 822.9 are distinguished for their small dimensions. They are mounted by countersunk screws.

The Stainless Steel-Mini indexing plungers present an affordable alternative to the GN 608.5 (see page) and GN 608.6 (see page 779) Stainless Steel-Indexing plungers.

In types C and CN, the button can be turned by 30° after retracting the indexing pin, holding it in the „retracted“ position using the indexing lock.

- Range of indexing plungers (see page 738)

TECHNICAL INFORMATION

- ISO-Fundamental tolerances (see page A21)
- Stainless Steel characteristics (see page A26)
- Plastic characteristics (see page A2)
- Load rating information (see page A42)

ON REQUEST

- with red knob

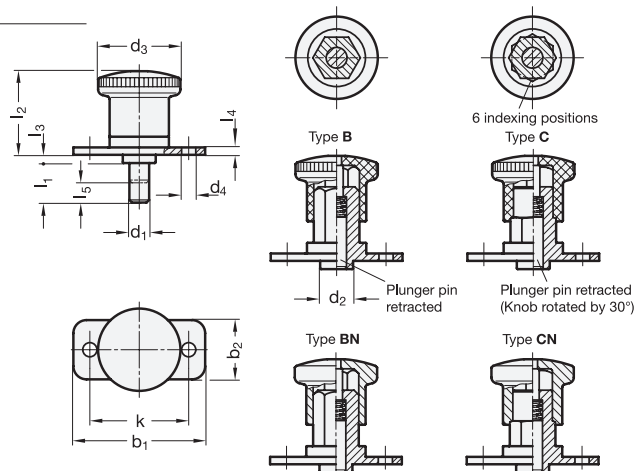



Indexing elements

GN 822.9-B/C

STAINLESS STEEL

Description	d1 Bore +0.03/+0.08 Pin h9	l1	b1	b2	d2	d3	d4	k	l2	l3	l4	l5	Spring load in N ≈ initial	Spring load in N ≈ end	
GN 822.9-4-5-B	4	5	35	15	8	21	4.3	25	20.5	2	2	5	4	12	23
GN 822.9-4-10-B	4	10	35	15	8	21	4.3	25	20.5	2	2	5	4	12	23
GN 822.9-5-6-B	5	6	40	18	10	25	4.3	30	25.5	2.5	2	6	6	16	40
GN 822.9-5-12-B	5	12	40	18	10	25	4.3	30	25.5	2.5	2	6	6	16	41
GN 822.9-6-6-B	6	6	40	18	10	25	4.3	30	25.5	2.5	2	6	6	16	40
GN 822.9-6-12-B	6	12	40	18	10	25	4.3	30	25.5	2.5	2	6	6	16	42
GN 822.9-8-10-B	8	10	50	23	14	33	5.3	38	35	2.5	3	10	11	35	100
GN 822.9-8-20-B	8	20	50	23	14	33	5.3	38	35	2.5	3	10	11	35	105
GN 822.9-10-10-B	10	10	50	23	14	33	5.3	38	35	2.5	3	10	11	35	103
GN 822.9-10-20-B	10	20	50	23	14	33	5.3	38	35	2.5	3	10	11	35	109
GN 822.9-4-5-C	4	5	35	15	8	21	4.3	25	20.5	2	2	5	4	12	23
GN 822.9-4-10-C	4	10	35	15	8	21	4.3	25	20.5	2	2	5	4	12	24
GN 822.9-5-6-C	5	6	40	18	10	25	4.3	30	25.5	2.5	2	6	6	16	40
GN 822.9-5-12-C	5	12	40	18	10	25	4.3	30	25.5	2.5	2	6	6	16	41
GN 822.9-6-6-C	6	6	40	18	10	25	4.3	30	25.5	2.5	2	6	6	16	40
GN 822.9-6-12-C	6	12	40	18	10	25	4.3	30	25.5	2.5	2	6	6	16	42
GN 822.9-8-10-C	8	10	50	23	14	33	5.3	38	35	2.5	3	10	11	35	99
GN 822.9-8-20-C	8	20	50	23	14	33	5.3	38	35	2.5	3	10	11	35	103
GN 822.9-10-10-C	10	10	50	23	14	33	5.3	38	35	2.5	3	10	11	35	102
GN 822.9-10-20-C	10	20	50	23	14	33	5.3	38	35	2.5	3	10	11	35	108

GN 822.9-BN/CN

STAINLESS STEEL

Description	d1 Bore +0.03/+0.08 Pin h9	l1	b1	b2	d2	d3	d4	k	l2	l3	l4	l5	Spring load in N ≈ initial	Spring load in N ≈ end	
GN 822.9-4-5-BN	4	5	35	15	8	21	4.3	25	20.5	2	2	5	4	12	37
GN 822.9-4-10-BN	4	10	35	15	8	21	4.3	25	20.5	2	2	5	4	12	37
GN 822.9-5-6-BN	5	6	40	18	10	25	4.3	30	25.5	2.5	2	6	6	16	64
GN 822.9-5-12-BN	5	12	40	18	10	25	4.3	30	25.5	2.5	2	6	6	16	65
GN 822.9-6-6-BN	6	6	40	18	10	25	4.3	30	25.5	2.5	2	6	6	16	65
GN 822.9-6-12-BN	6	12	40	18	10	25	4.3	30	25.5	2.5	2	6	6	16	66
GN 822.9-8-10-BN	8	10	50	23	14	33	5.3	38	35	2.5	3	10	11	35	146
GN 822.9-8-20-BN	8	20	50	23	14	33	5.3	38	35	2.5	3	10	11	35	150
GN 822.9-10-10-BN	10	10	50	23	14	33	5.3	38	35	2.5	3	10	11	35	149
GN 822.9-10-20-BN	10	20	50	23	14	33	5.3	38	35	2.5	3	10	11	35	155
GN 822.9-4-5-CN	4	5	35	15	8	21	4.3	25	20.5	2	2	5	4	12	37
GN 822.9-4-10-CN	4	10	35	15	8	21	4.3	25	20.5	2	2	5	4	12	37
GN 822.9-5-6-CN	5	6	40	18	10	25	4.3	30	25.5	2.5	2	6	6	16	64
GN 822.9-5-12-CN	5	12	40	18	10	25	4.3	30	25.5	2.5	2	6	6	16	65
GN 822.9-6-6-CN	6	6	40	18	10	25	4.3	30	25.5	2.5	2	6	6	16	47
GN 822.9-6-12-CN	6	12	40	18	10	25	4.3	30	25.5	2.5	2	6	6	16	66
GN 822.9-8-10-CN	8	10	50	23	14	33	5.3	38	35	2.5	3	10	11	35	146
GN 822.9-8-20-CN	8	20	50	23	14	33	5.3	38	35	2.5	3	10	11	35	150
GN 822.9-10-10-CN	10	10	50	23	14	33	5.3	38	35	2.5	3	10	11	35	148
GN 822.9-10-20-CN	10	20	50	23	14	33	5.3	38	35	2.5	3	10	11	35	154