

PMW.



Assembly plates on profiles with T-slot for CFSW. and CFMW. hinges



ELESA Original design

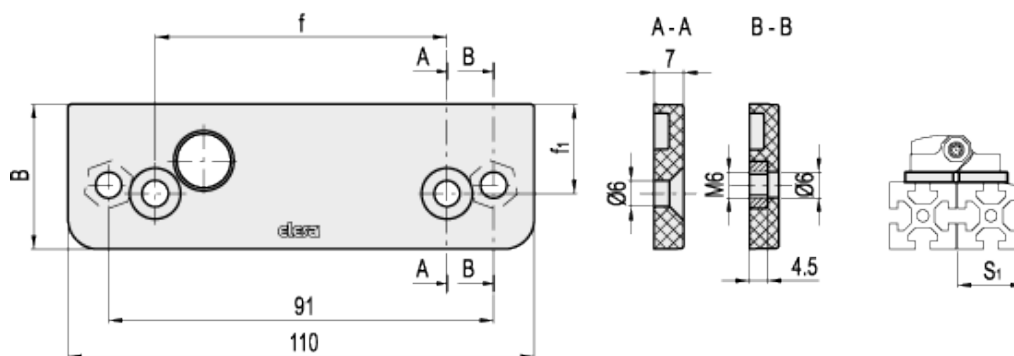

technical informations

Plate

Polyamide based (PA) high-rigidity SUPER-technopolymer, black colour, matte finish.
Resistant to solvents, oils, greases and other chemical agents.

Screws and nuts

AISI 304 stainless steel.

Features and applications

PMW assembly plates allow the mounting of CFSW.110 and CFMW.110 hinges on standard aluminium profiles of 30, 35, 40, 45 and 50 mm with T-slot.

The mounting on aluminium profiles of 40 mm can also be performed without the use of assembly plates.

The fixing screws of the plates to the profile are not accessible after the assembly of the hinges (Fig. 1). Therefore, even with the use of PMW assembly plates, CFSW. and CFMW. hinges remain tamperproof.

The supply of the plate includes:

- PMW: 2 countersunk screws M6x12 (for CFSW.110).
- PMW-M: 2 countersunk screws M6x14 (for CFMW.110).
- 2 M6 hexagonal nuts, assembled into the plate, necessary for the fixing of the hinge to the plate.

Plates of different dimensions can be combined in case of door and doorframe made with profiles of different dimensions (Fig.2).

Assembly instructions

- Fix the plates on the profile in the desired position by using M6 countersunk head screws (not included in the supply) and the relative dowels for T-slot type [GN 505](#) (not included in supply).
- Fit CFSW.110 or CFMW.110 hinge (fig. 1) on the relative plates by using M6 countersunk head screws (included in the supply).
- Place the closing caps properly (included in the supply of the hinge).

Technical data

The use of PMW plates, properly assembled as indicated in the assembly instructions, guarantees the max limit static load of CFSW. and CFMW. hinges.

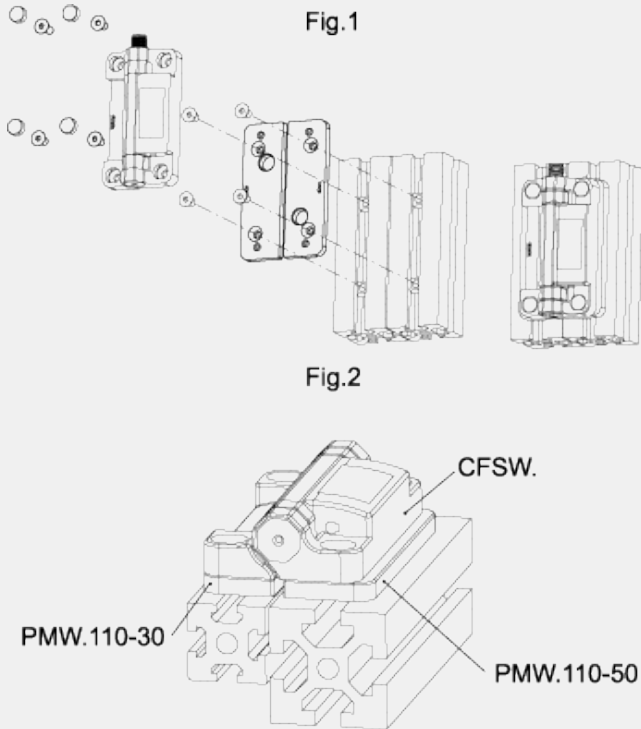

Standard Elements		Profile	Main dimensions			Weight	For hinges
Code	Description	S ₁	B	f	f ₁	g	
51901	PMW.110-30	30	28	73	14.5	34	CFSW.110
51903	PMW.110-35	35	28	72	16.5	34	CFSW.110
51904	PMW.110-40	40	28	70.5	19	34	CFSW.110
51905	PMW.110-45	45	34	69	21	39	CFSW.110
51907	PMW.110-50	50	34	69	24	39	CFSW.110

Standard Elements		Profile	Main dimensions				Weight	For hinges
Code	Description	S ₁	B	f	f ₁	l	g	
51901-M	PMW.110-30-M	30	28	73	14.5	14	35	CFMW.110
51903-M	PMW.110-35-M	35	28	72	16.5	14	35	CFMW.110
51904-M	PMW.110-40-M	40	28	70.5	19	14	35	CFMW.110
51905-M	PMW.110-45-M	45	34	69	21	14	40	CFMW.110
51907-M	PMW.110-50-M	50	34	69	24	14	40	CFMW.110



